

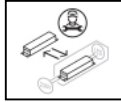

Installationsanvisning / Assembly instruction
Art nr: 120813 / 120813D

Ljuskällan och drivdonet i denna armatur får endast bytas ut av tillverkaren eller av tillverkaren utsedd person.
 The light source and control gear contained in this luminaire shall only be replaced by the manufacturer or a person designated by the manufacturer.

Denna produkt innehåller en ljuskälla med energieffektivitetsklass C / This product contains a light source of energy efficiency class C

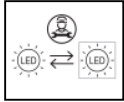

120813
 120813D

⚠ Armaturen ska monteras av behörig installatör.

Viktigt: Bryt spänningen före installation.

Installation:

1. Försäkra er om att spänning och frekvens på armaturen och nätet överensstämmer.
2. Montera armaturen på vajer enligt (fig.1). Var noga med att vajern hamnar mellan brickor och fäste.
3. Anslut till kopplingsplinten (A) i dosan (anslutningskabel medföljer ej).
4. Ställ in önskad vinkel, och lås sedan fast armaturhuset med skruv (B) (fig.2).

⚠ Installation must be carried out by a qualified electrician.

Important: Switch off the mains voltage before Installation.

Installation:

1. Ensure that voltage and Hz on the fixture and mains voltage are the same.
2. Mount the fixture on the wires according to (fig.1). Be sure that the wire run in the track on the trays.
3. Connect the cable to the terminal block (A) (installation cable is not included).
4. Set the desired angle and then lock the housing with the screw (B) (fig.2).

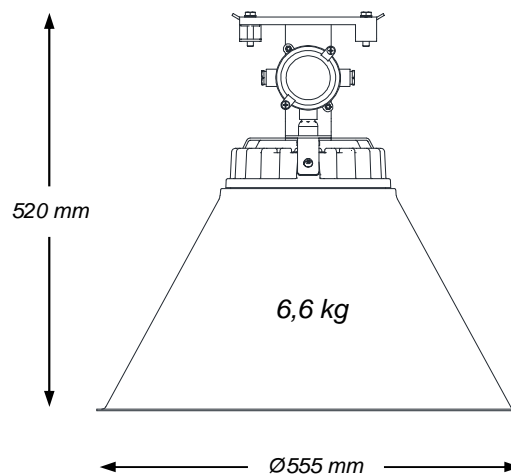

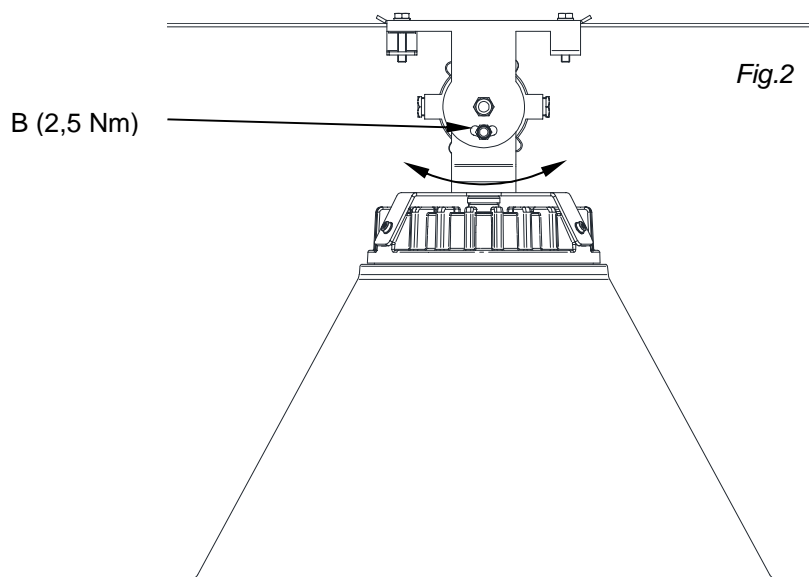
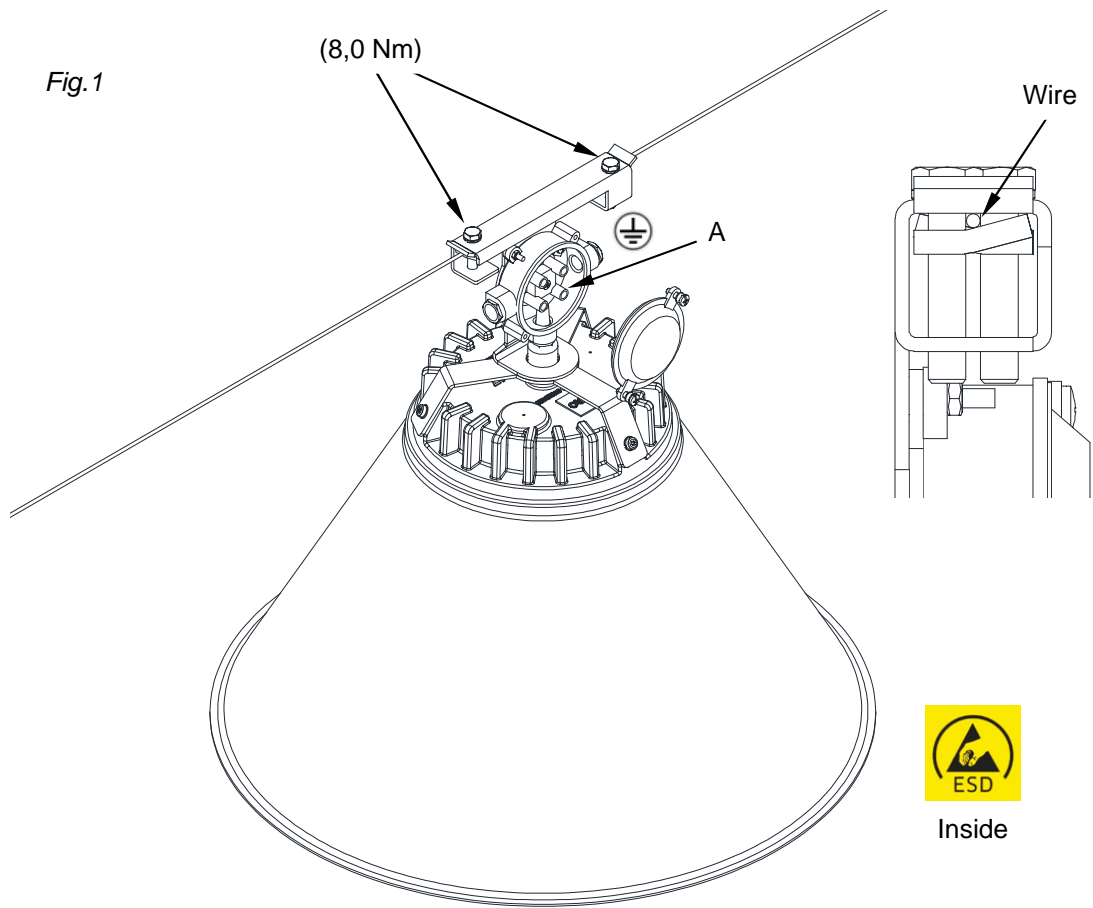

Rengöringsinstruktioner och återvinningsanvisningar finns på www.zero.se
Cleaning and recycling instructions are available at www.zerolighting.com